



## Installation instructions

Akrapovič Exhaust Systems

**Slip-On**

for the

**Honda CBR 600RR**

**Honda CBR 600RR ABS**

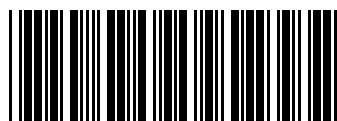

\*502248\*

[www.akrapovic.com](http://www.akrapovic.com)

**Congratulations on purchasing an Akrapovič exhaust system. Please read these installation instructions carefully. If you have any trouble installing the system please contact your authorized dealer!**

## **IMPORTANT INFORMATION**

### **Exclusion of Certain Liability**

1. The manufacturer, importer or dealer shall not be liable for any incidental damage including personal injury or any other damages caused by improper installation or operation of the Akrapovič exhaust system. When installing the Akrapovič exhaust system be careful that the exhaust system does not touch other parts sensitive to high temperature.
2. Akrapovič makes no representation or warranties with regard to damage caused by the improper installation, use and maintenance of the Akrapovič exhaust system. The warranty is limited to defects recognized by our technical department and due to normal use, and excludes items subject to normal wear (gaskets and damping wool). The guarantee is void in case of accident, modification, improper or competition use.
3. Do not attempt to install the Akrapovič exhaust system on a vehicle model for which it was not made or tested by Akrapovič.
4. When the exhaust system gets very hot during operation, be careful not to burn yourself on the exhaust system or parts which are in direct contact with it, even when the engine is not running. Also protect other people, especially children, from the injuries mentioned above.
5. In some cases Akrapovič exhaust system kits contain chemical products (ceramic anti-seizing grease; bolt sealant). Handle with care, do not inhale or swallow. Avoid excessive contact with skin, eyes or mucous membranes. Keep out of reach of children.
6. Technical specifications of Akrapovič exhaust systems and related products are subject to change without notice.

### **Trademarks**

The Akrapovič Exhaust System Technology logo is a registered trademark of Akrapovič d.d.

### **Akrapovič website**

Information about Akrapovič exhaust systems and related products is available on the Akrapovič website at:

**<http://www.akrapovic.com>**

### **Copyright**

No part of the Akrapovič exhaust system or its documentation may be reproduced or distributed in any form or by any means without the prior written authorization of the Akrapovič company.

© Akrapovič, d.d. All rights reserved.

### **Symbols**

The following symbols are used throughout these installation instructions:



**TOOLS REQUIRED**



**TIGHTENING TORQUE**



**INSTALLATION TIP**



**CAUTION OR WARNING**



**USE BOLT SEALANT;** Apply 3 to 4 small drops of bolt sealant onto the cleaned and degreased threads before tightening the bolts. **WARNING! Avoid contact with skin, eyes and mucous membranes. Do not inhale fumes. Keep out of reach of children.**



**USE ANTI-SEIZE LEAD-FREE COPPER PASTE** (black tube); Provides trouble-free and long-lasting protection against seizing, corrosion and rusting of bolts, threaded ends, nuts, joints, etc. Also protects against vibration, wear and impact. **WARNING! Avoid eye contact. Avoid excessive skin contact. Keep out of reach of children.**



**USE ANTI-SEIZING GREASE** (white tube); Prevents seizing, corrosion and excessive wear between the titanium components of your exhaust system. **WARNING! Avoid eye contact. Avoid excessive skin contact. Keep out of reach of children.**

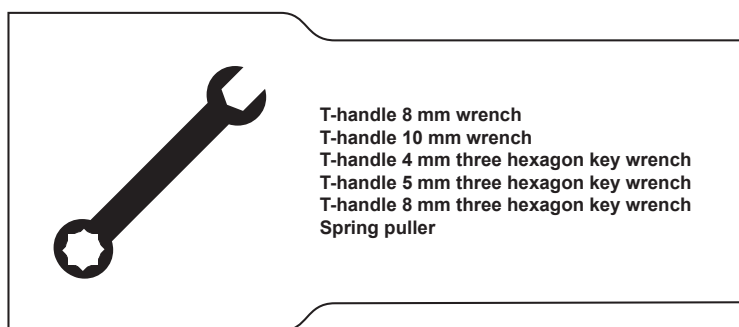

**BEFORE INSTALLING, CHECK SCHEMATIC OF THE EXHAUST SYSTEM!**



**IF ANY ITEMS IN THE AKRAPOVIČ EXHAUST SYSTEM PACKAGE ARE MISSING, PLEASE CONTACT YOUR AUTHORIZED DEALER. KEEP THE SCHEMATIC FOR FUTURE REFERENCE.**



**THESE INSTALLATION INSTRUCTIONS MUST BE READ CAREFULLY IN ORDER TO ENSURE PROPER INSTALLATION AND OPERATION OF THE AKRAPOVIČ EXHAUST SYSTEM.**



**THE EXHAUST SYSTEM CAN BE EXTREMELY HOT. ALLOW THE EXHAUST AND ENGINE TO COOL DOWN BEFORE BEGINNING INSTALLATION.**



**WE ADVISE YOU TO LEAVE INSTALLATION TO A QUALIFIED SERVICEMAN. IMPROPER INSTALLATION MAY RESULT IN A SHORTER LIFETIME OF THE EXHAUST SYSTEM AND/OR DAMAGE TO THE VEHICLE.**

**REMOVAL OF STOCK EXHAUST SYSTEM:**

1. Put the motorcycle on a side stand, we recommend a racing stand. Make sure, that surface is solid and flat.
2. Remove the passenger's and rider's seat (Figure 1, 2).



Figure 1



Figure 2

3. Unscrew four marked bolts from the seat cowling and remove the seat cowling (**Figure 3**).



Figure 3

4. Unscrew and remove the licence plate holder with rear light and turn signal lamps. Disconnect the electrical leads first (**Figure 4, 5**).

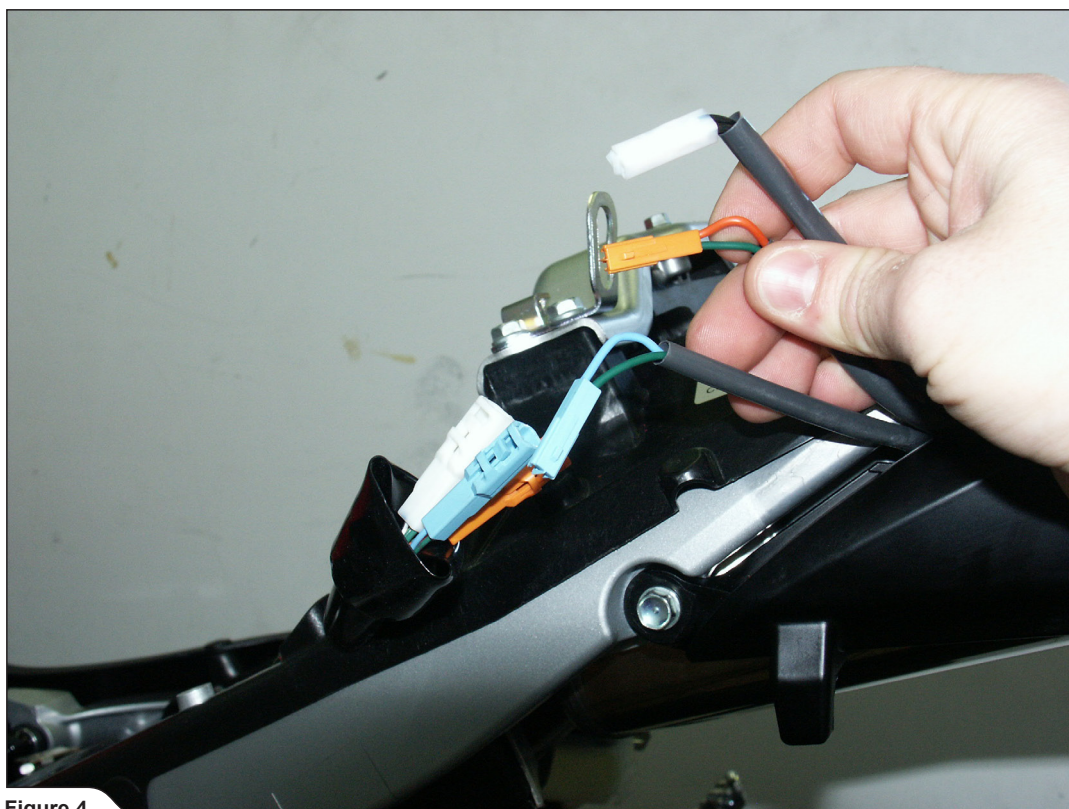

Figure 4

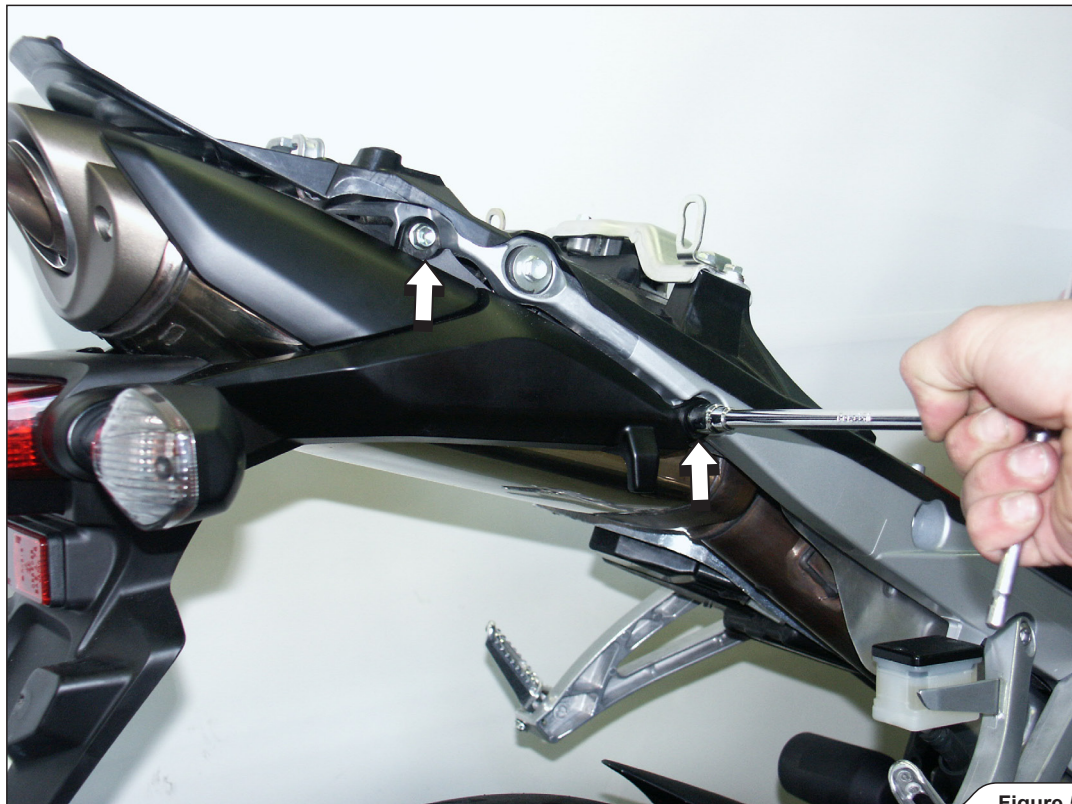

Figure 5

5. Unscrew the passenger's footrest bracket, plastic heat shield cover, aluminium heat shield and the bolts from the rider's footrest bracket (Figure 6, 7, 8, 9, 10, 11).  
**!** **WARNING:** do not disconnect the brake fluid tube!



Figure 6



Figure 7



Figure 8

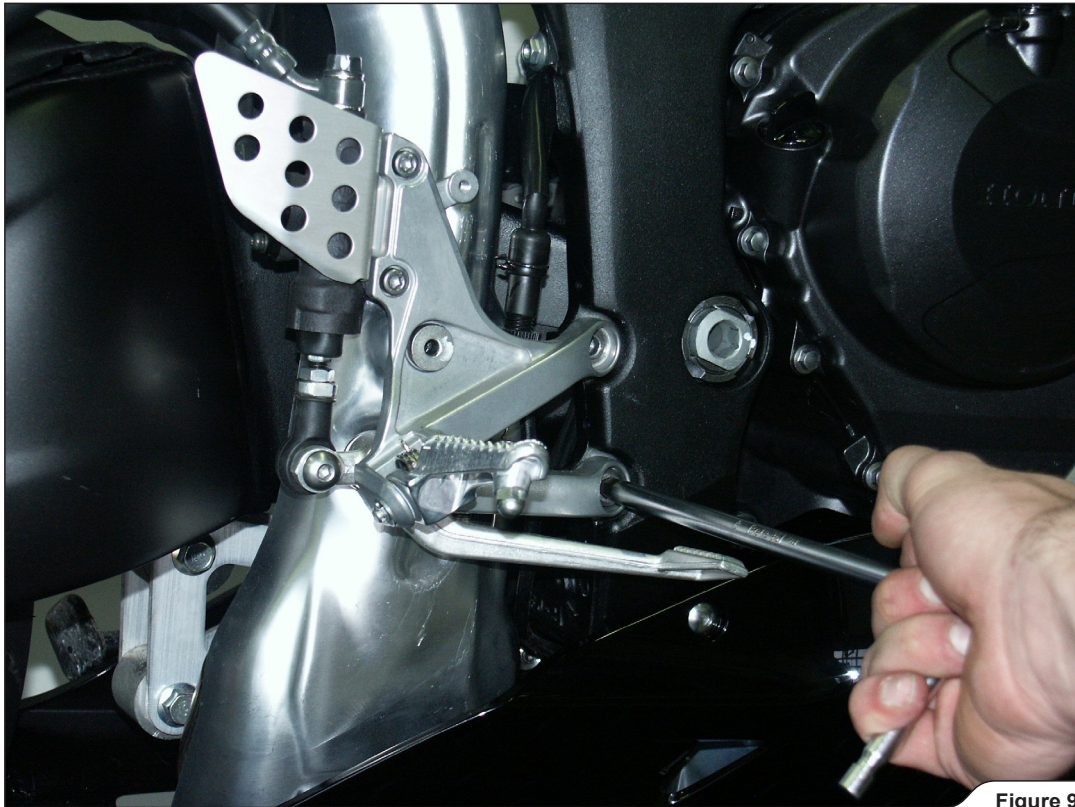

Figure 9



Figure 10





Figure 11

6. Unscrew the bolts from the link-pipe bracket (**Figure 12**), link-pipe/collector joint metal clamp (**Figure 13**) and muffler brackets (**Figure 14**). Remove the muffler with welded link-pipe and stock graphite gasket.



Figure 12



Figure 13



Figure 14

**INSTALLATION OF THE AKRAPOVIČ SLIP-ON EXHAUST SYSTEM:**

1. Coat the bolt and interior of metal clamp with Akrapovič anti-seize lead-free copper paste (black tube) and correctly install the metal clamp onto the Akrapovič independent link pipe (Figure 15). Slide the link pipe onto the stock collector (Figure 16).

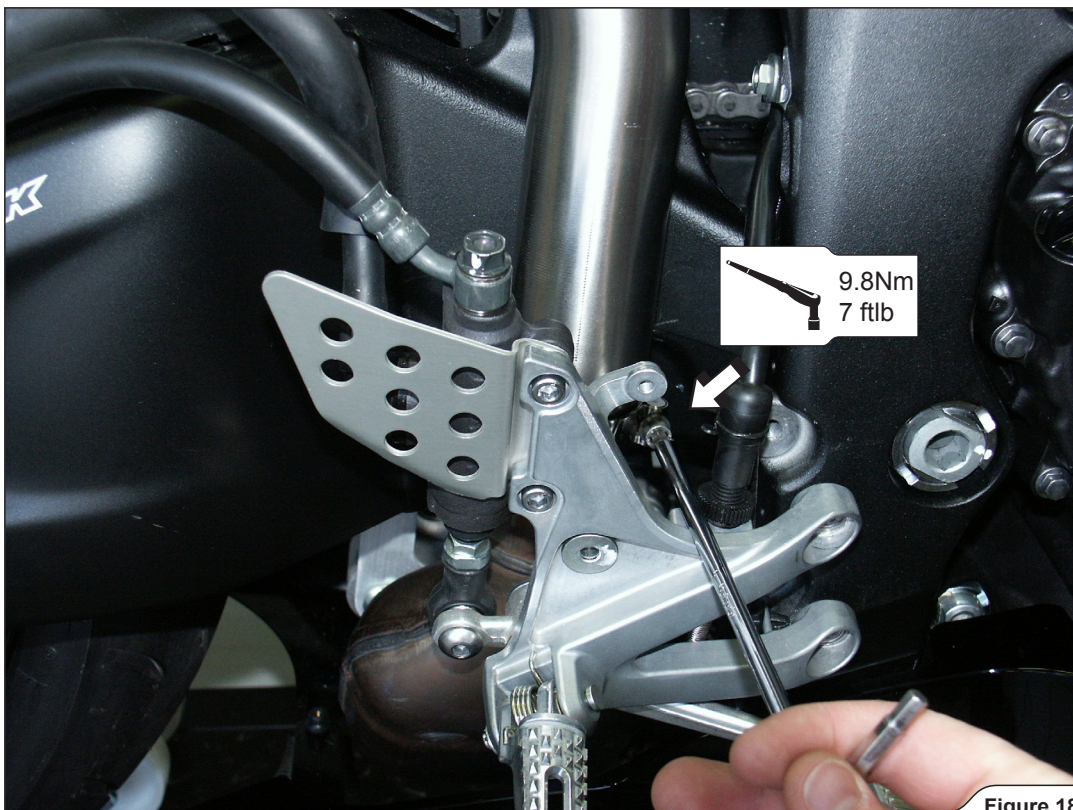

Figure 15



Figure 16

2. Attach the link pipe bracket (**Figure 17**). Tighten the metal clamp at the independent link pipe – stock collector connection (**Figure 18**). Make sure the link pipe is not touching the frame and other parts.



3. Attach the stock aluminium heat shield, rider's and passenger's footrest and plastic heat shield cover in the reverse order from the order in which they were removed (**Figure 19, 20, 21**).



Figure 19

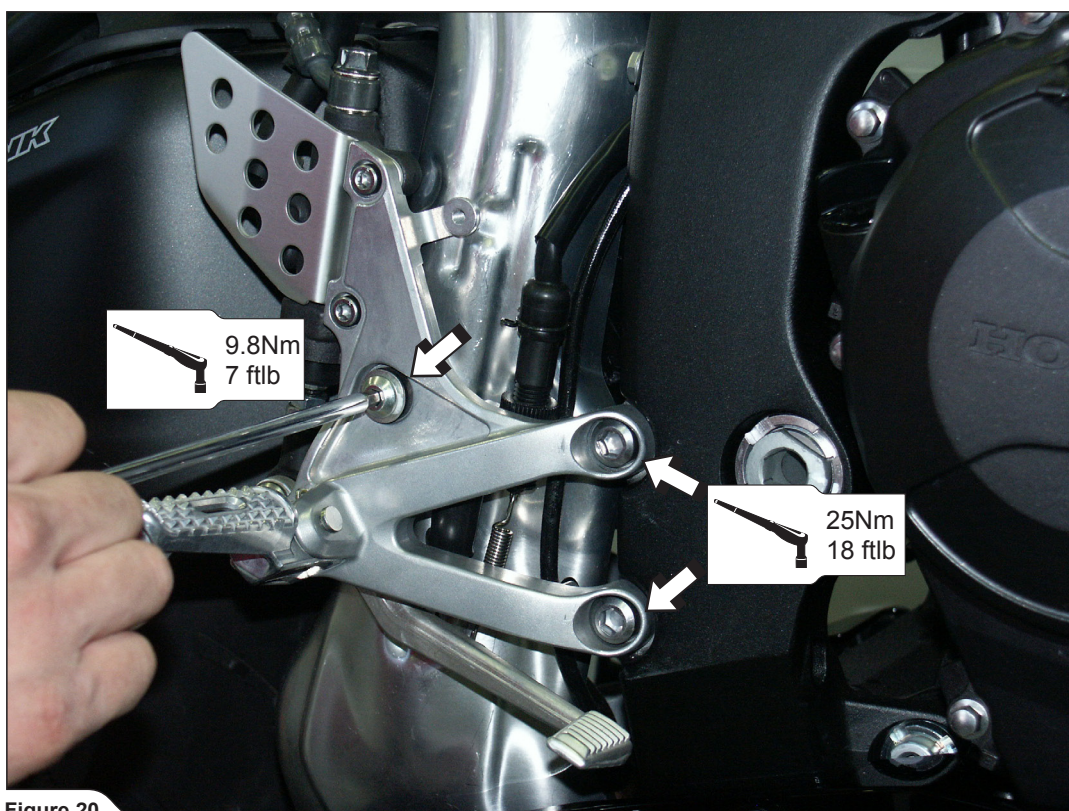

Figure 20

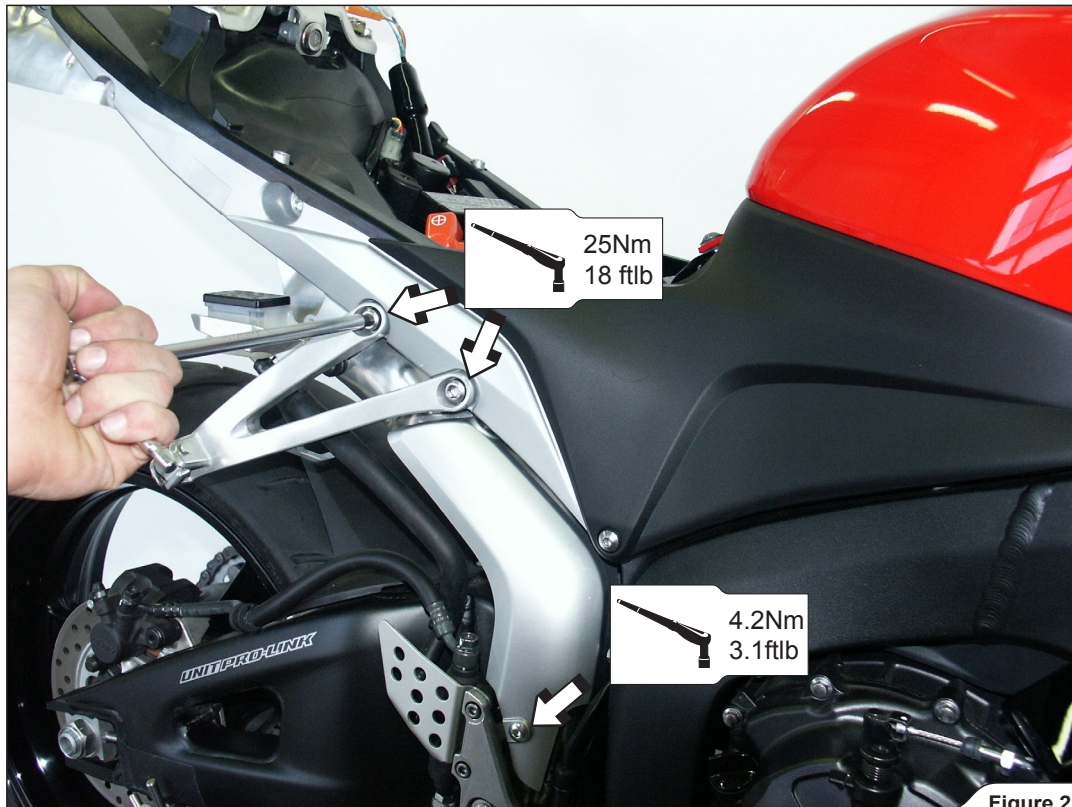

Figure 21

4. Attach the upper part of Akrapovič carbon-fiber clamp onto the subframe. Use stock bolts (Figure 22, 23).
- ✘ Bend the stock aluminium heat shield upwards by 2-5mm (or just enough that shield does not touch the Akrapovič muffler!) (Figure 24).

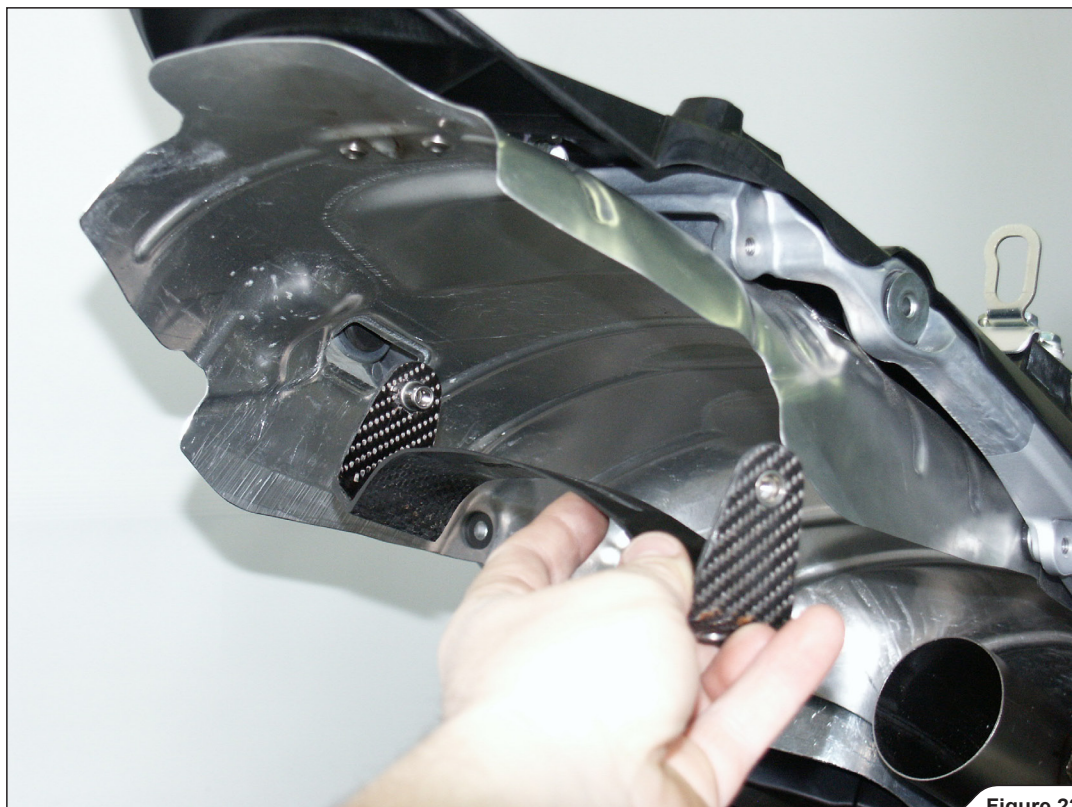

Figure 22

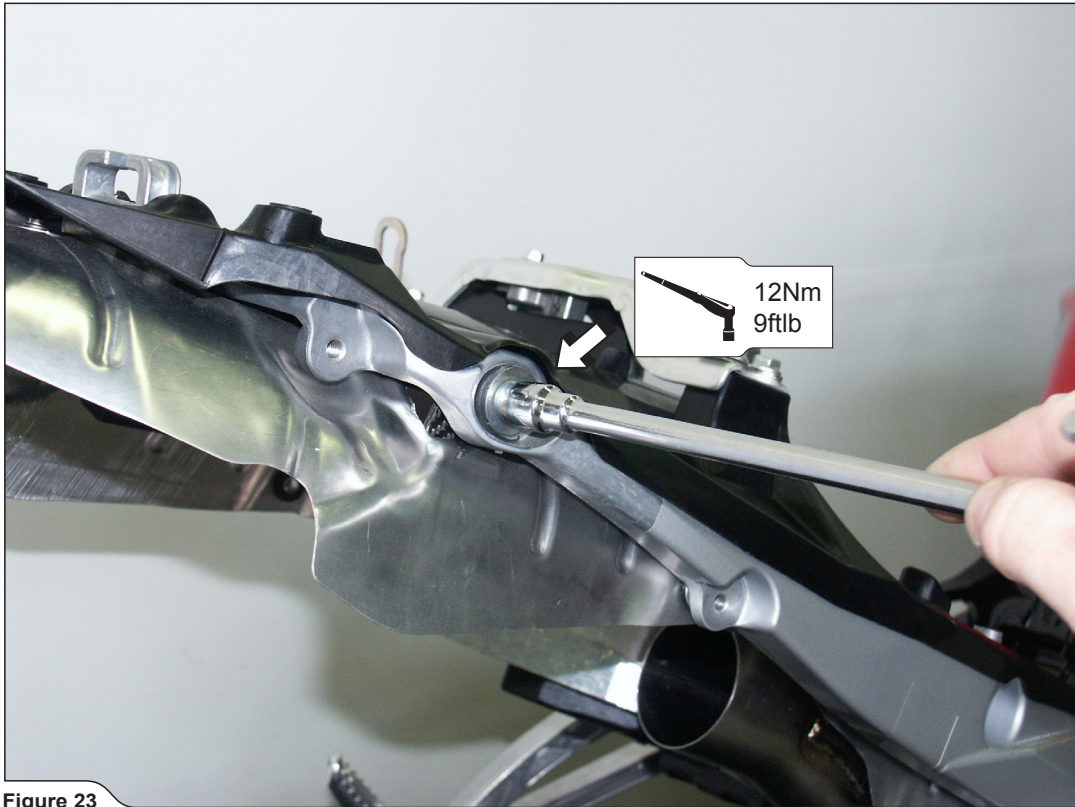

Figure 23



Figure 24

5. Position the muffler correctly and slide it onto the outlet side of the link pipe (**Figure 25**). For optional titanium independent link pipe only: coat the interior side of the input of the muffler with Akrapovič ceramic anti-seizing grease (white tube).



Figure 25

6. Position and attach the spring (**Figure 26**). Tighten the lower part of the Akrapovič carbon-fiber muffler clamp (**Figure 27**).  
**!** **WARNING:** make sure, that springs pull the muffler all the way onto the link pipe – use rubber mallet if necessary to tap the connections into place!



Figure 26





Figure 27

7. Attach the licence plate holder with rear light and turn signal lamps (connect the electrical leads), passenger's and rider's seat and seat cowling (tightening torque 9.8 Nm / 7 ftlb) in the reverse order from the order in which they were removed (Figure 28, 29, 30, 31, 32).

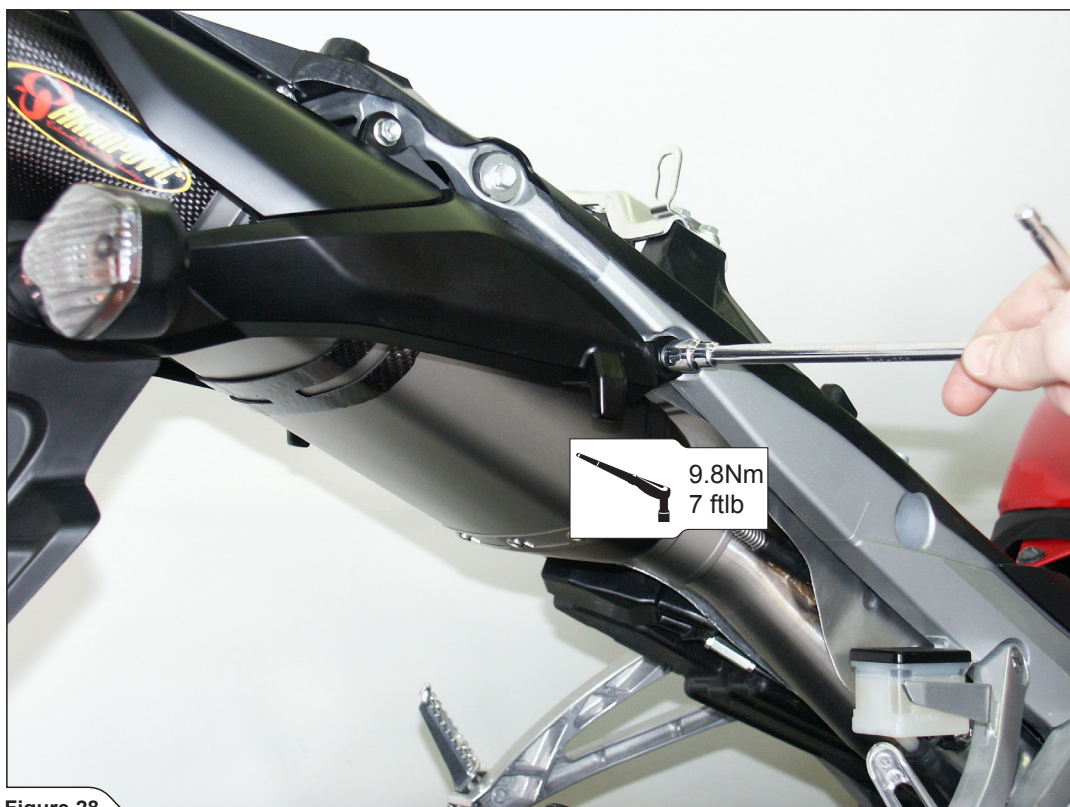

Figure 28



Figure 29



Figure 30



Figure 31



Figure 32

**Final installation:**

1. Clean grease spots:
  - a. Muffler - titanium outer sleeve: use a soft cloth sprayed with a multi-purpose spray lubricant (WD-40 or equivalent).
  - b. SLIP-ON with stainless steel link pipe: use a soft cloth sprayed with a contact cleaner, then wipe with a soft dry cloth.
  - c. SLIP-ON with titanium link pipe: use a soft cloth sprayed with a multi-purpose spray lubricant (WD-40 or equivalent).

Cleaning will prevent spots from burning onto the surface. Do not use aggressive chemical cleaners, because they can damage the sticker.

**! WARNING: make sure all the bolts are sufficiently tightened. In case the exhaust system touches the cowling or other parts repeat the adjustment of the exhaust system or contact your authorized dealer.**

**! IT IS NORMAL IF WHITE SMOKE COMES OUT OF THE MUFFLER ON FIRST OPERATION.**

**! DO NOT STAND BEHIND THE MUFFLER ON FIRST OPERATION.**

**! DO NOT USE AUTOMOTIVE WHEEL CLEANERS OR ANY CLEANING PRODUCTS WHICH CONTAIN ACIDIC ADDITIVES TO CLEAN AKRAPOVIČ EXHAUST SYSTEMS.**

**MAINTENANCE OF THE AKRAPOVIČ EXHAUST SYSTEM**

1. Clean the titanium exhaust components with a multi-purpose spray lubricant (WD-40 or equivalent ), carbon fiber exhaust components with soft and dry cloth and stainless steel components with soft cloth sprayed with contact cleaner, then wipe with soft and dry cloth. A change in the color of the exhaust system is normal due to the high temperatures.
2. Periodically make sure all the bolts and springs are sufficiently tight.

**HONDA CBR 600 RR, SLIP-ON exhaust system**  
**Product code: S-H6SO11-ACT**  
**S-H6SO11T-ACT**

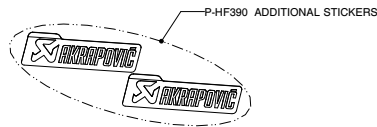
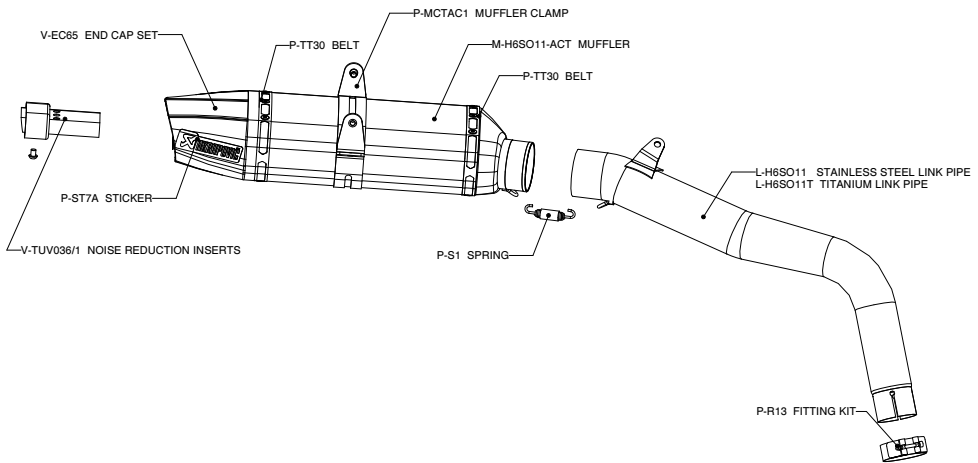

MUFFLER REPAIR KITS	
REPACK	P-RPCK3
SLEEVE	P-RKS145ACT27

**HONDA CBR 600 RR, SLIP-ON exhaust system / Street legal**  
**Product code: S-H6SO11-HACT**  
**S-H6SO11T-HACT**

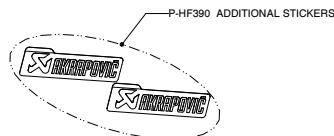
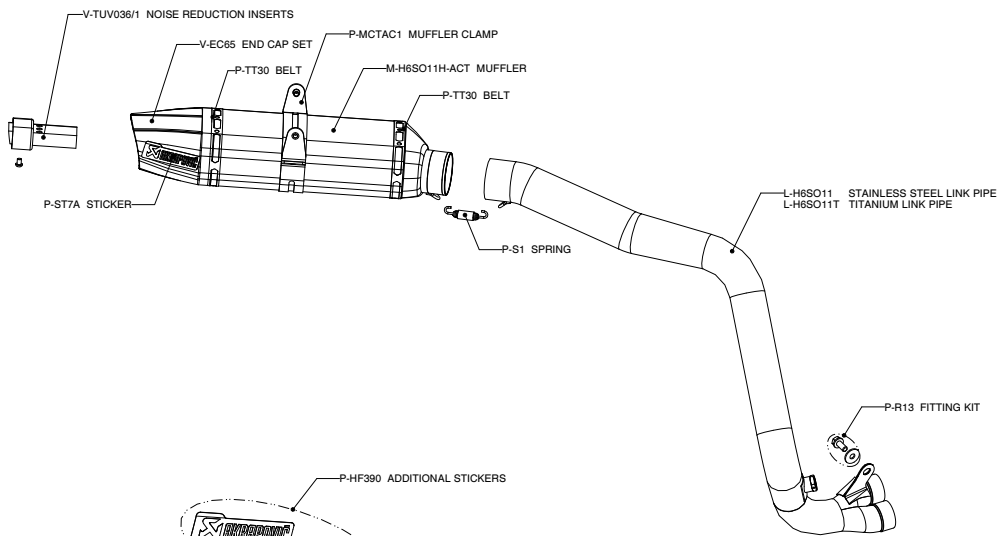

MUFFLER REPAIR KITS	
REPACK	P-RPCK3
SLEEVE	P-RKS145ACT27

**HONDA CBR 600 RR Complete exhaust system/ RACING LINE, tube set with Street legal SLIP on Mufflers, model year: 2007-2008**  
**HONDA CBR 600 RR Complete exhaust system/ EVOLUTION LINE, tube set with Street legal SLIP on Mufflers, model year: 2007-2008**

**Product code: S-H6R9-ACT/1**  
**S-H6RFT9T-ACT/1**

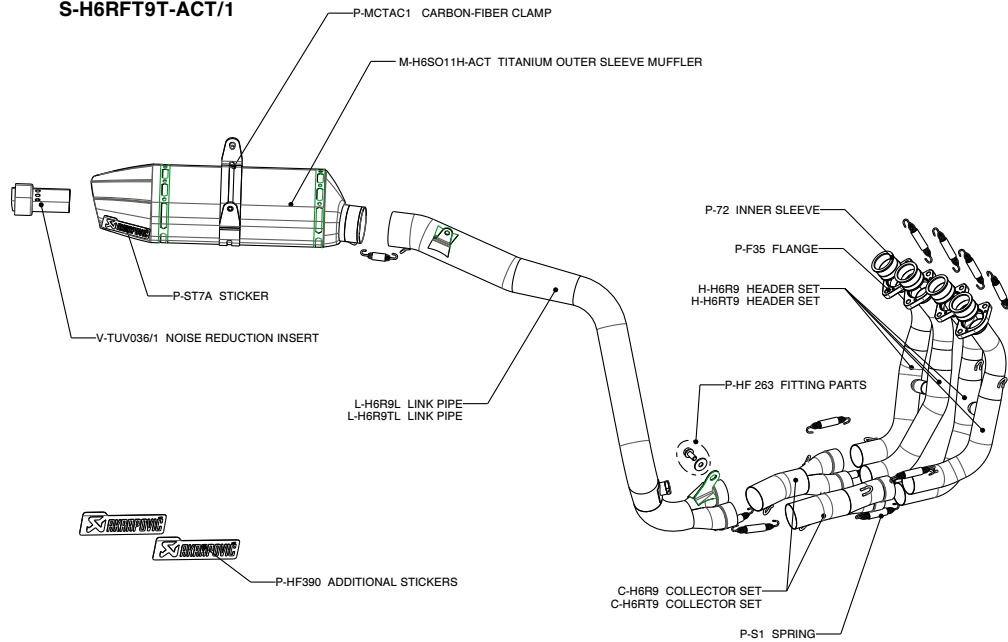

**WARNING! IN CASE OF COMBINATION WITH RACING OR EVOLUTION TUBE SET, THE SLIP-ON HOMOLOGATION IS NOT VALID!**

**HONDA CBR 600 RR, SLIP-ON exhaust system**  
**Product code: S-H6SO13-ACT**  
**S-H6SO13T-ACT**

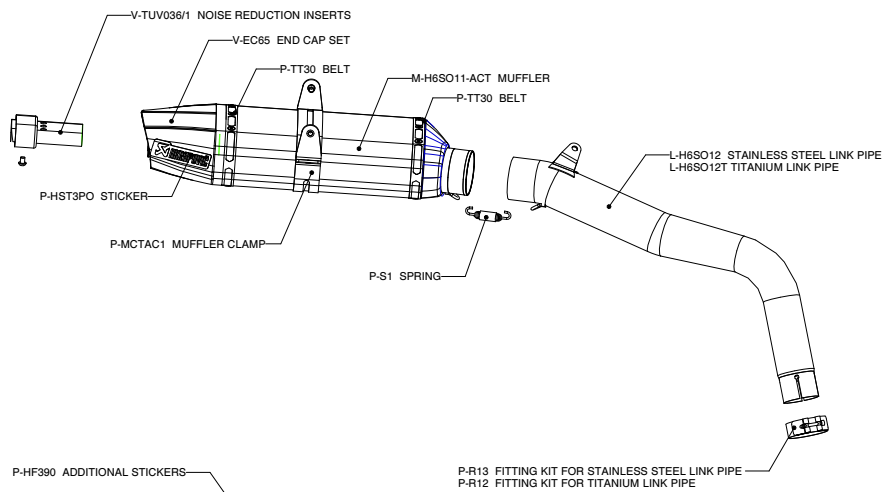

MUFFLER REPAIR KITS	
REPACK	P-RPCK3
SLEEVE	P-RKS145ACT27

**HONDA CBR 600 RR, SLIP-ON exhaust system / Street legal**  
**Product code: S-H6SO13-HACT**  
**S-H6SO13T-HACT**

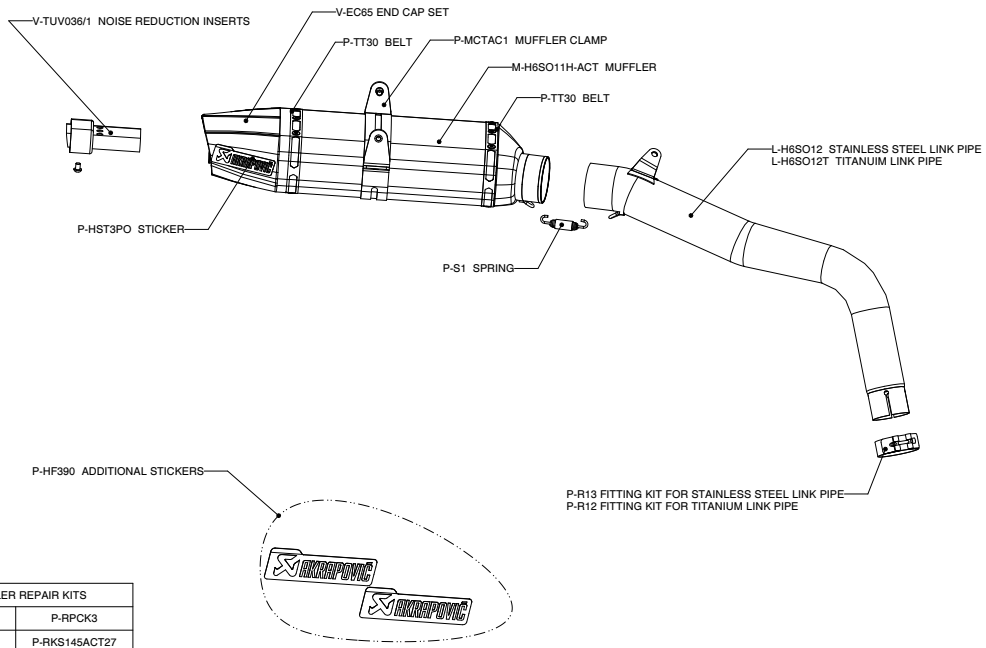

**HONDA CBR 600 RR Complete exhaust system/ RACING LINE, tube set with Street legal SLIP on Mufflers**  
**HONDA CBR 600 RR Complete exhaust system/ EVOLUTION LINE, tube set with Street legal SLIP on Mufflers**  
**Product code: S-H6R10-ACT/1**  
**S-H6RFT10-ACT/1**

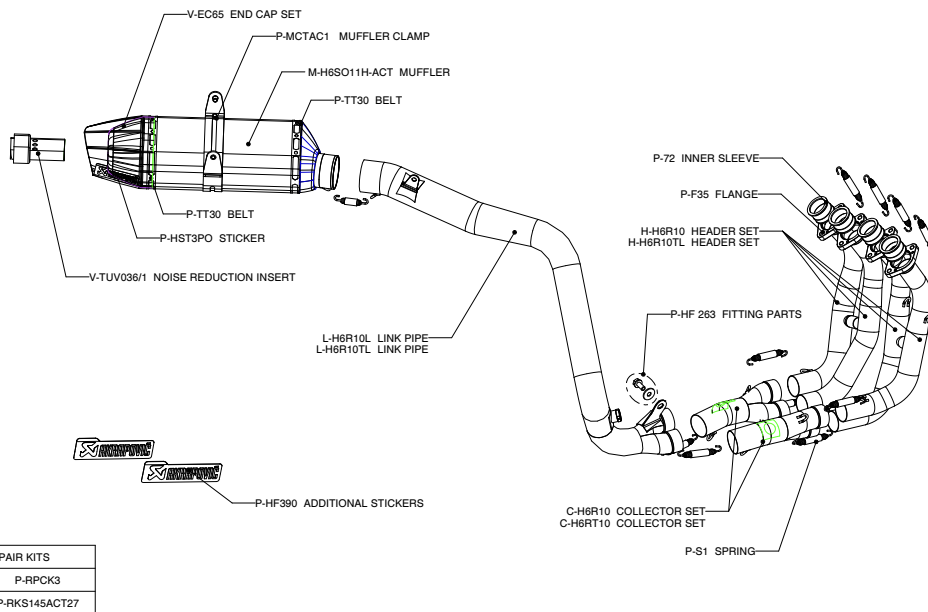

**WARNING! IN CASE OF COMBINATION WITH RACING OR EVOLUTION TUBE SET, THE SLIP-ON HOMOLOGATION IS NOT VALID!**

